

(LSW)

(RSW)

ANCHOR BOLT PLAN  
 UP TO 1.000m. HIGH BRICK WALL &  
 ABOVE CLADDING ALL AROUND THE BUILDING

**DRAWING CROSS REFERENCE**

Drawing No:	Rev.	Description

**IMPORTANT NOTES:**

ANCHOR BOLT LOCATIONS HAVE TO BE VERIFIED & CERTIFIED BY COMPETENT AUTHORITY FOR ACCURACY AT SITE

LEVELS AS MARKED IN DETAILS TO BE CONFIRMED BY CLIENT/CONSULTANT & TO BE CROSS-CHECKED AT SITE BEFORE ERECTION.

GRADE OF CONCRETE SHALL BE OF MINIMUM M25 U.N.O.

SIZES OF THE PEDESTAL SHOULD BE 50mm. MORE ON EITHER SIDE OF DIMENSION OF BASE PLATE

**LEGENDS:**

- LSW = LEFT SIDE WALL
- RSW = RIGHT SIDE WALL
- FEW = FRONT END WALL
- BEW = BACK END WALL

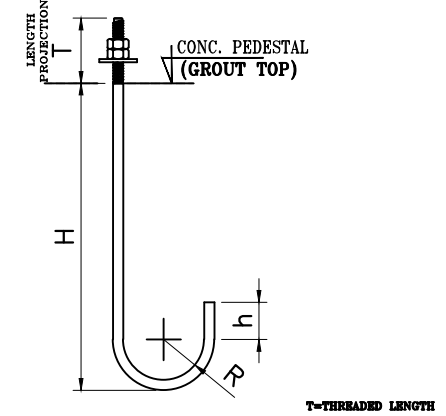

Rev.	Description	Name	Checked	Date

**REVISIONS**

**Project:** PRE-ENGINEERED BUILDING FOR AT \*\*\*\*

**Client:**

**Architect:**

**Consultant:**

**Drawing Title:** ANCHOR BOLT LAYOUT PLAN

<b>Drawn by:</b> N.S	<b>Scale:</b> N.T.S.	<b>Date:</b> 09.04.2016
<b>Checked by:</b> V.C	<b>Project No:</b> J-603	<b>Drawing No:</b> AB-001
<b>Approved by:</b>		<b>Revision:</b> R0